

# EQUIPMENT

Totem Ocean Trailer Express, Inc.

## Reliable, Competitive & Responsive

Totem Ocean Trailer Express, Inc. (TOTE) owns and operates unique diesel electric roll-on/roll-off trailerships between the Ports of Tacoma, Washington and Anchorage, Alaska.

Founded in 1975 TOTE has been serving our customers and the people of Alaska for over three decades. Our Orca Class vessels, brought into service in 2003, were "Built For Alaska" and have several features and redundancies which were specifically designed solely to service the Alaska trade.

**Corporate Headquarters**  
32001 - 32nd Ave. So., Suite 200  
Federal Way, Washington 98001  
Toll Free: 800.426.0074  
Direct: 253.449.8100  
Fax: 253.449.8225

**Tacoma Terminal Facility**  
500 Alexander Ave.  
Tacoma, Washington 98421  
Toll Free: 800.426.0074  
Direct: 253.238.8400  
Fax: 253.238.8401

**Anchorage Terminal Facility**  
2511 Tidewater  
Anchorage, Alaska 99501  
Toll Free: 800.234.8683  
Direct: 907.276.5868  
Fax: 907.278.0461

**Fairbanks Office**  
2142 Airport Way, 2nd Floor  
Fairbanks, Alaska 99701  
Direct: 907.452.1022  
Fax: 907.451.7610

**Houston Sales Office**  
635 Knipp Rd.  
Houston, Texas 77024  
Direct: 713.467.4086  
Fax: 713.935.0985

Totem Ocean Trailer Express, Inc.  
[www.totemocean.com](http://www.totemocean.com)



**Quality.** TOTE is committed to continual improvement through our Quality, Health, Safety, Environment and Security Programs. As testament to this commitment, we have received the following certifications:



# EQUIPMENT

Equipment choices to serve you.

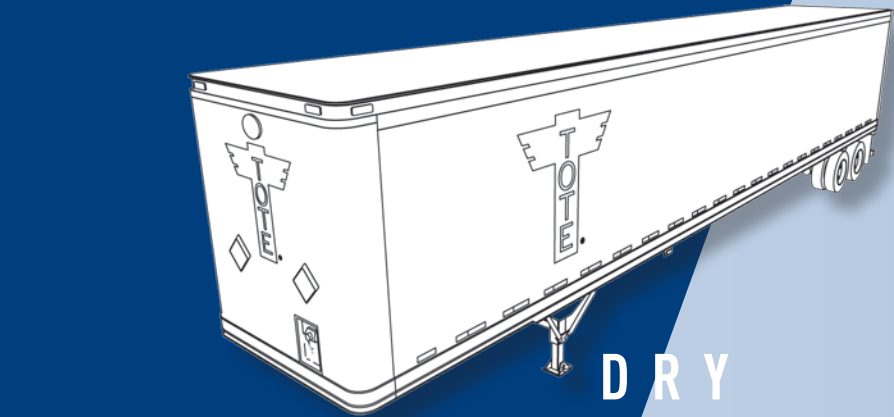

DRY



FLATBED

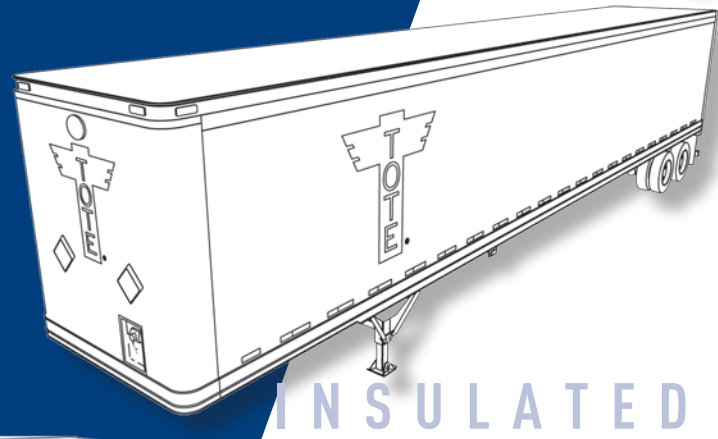

INSULATED

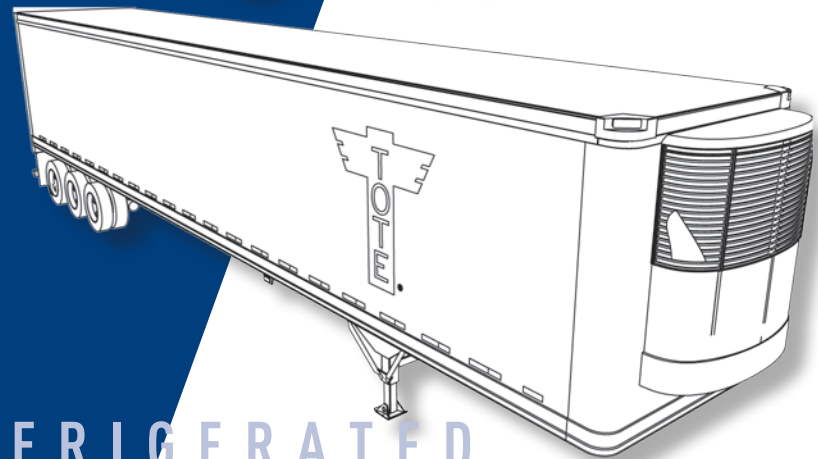

REFRIGERATED

Dry Equipment	Fleet Size	Capacity Cube	Capacity Weight	Interior Length	Interior Width	Interior Height	Door Width	Door Height	Axle Specifications
40' Trailer	75	2,679	49,967	39'6"	8'3"	8'3"	8'0"	8'2"	Tandem Axle
53' 102" Trailer	50	4,184	52,960	52'4"	8'5"	9'6"	8'2"	9'7"	Tandem Axle
53' 102" Trailer	29	4,184	56,040	52'4"	8'5"	9'6"	8'2"	9'7"	Triple Axle
40' Container With Chassis	77	2,650	46,380	39'5"	7'7"	8'10"	7'7"	8'6"	Tandem Axle
48' 102" Container With Chassis	30	3,489	48,033	47'5"	8'2"	8'11"	8'2"	8'5"	Tandem Axle
53' 102" Container With Chassis	19	3,823	48,400	52'6"	8'2"	8'11"	8'2"	8'3"	Tandem Axle

Flatbed Equipment	Fleet Size	Capacity Weight	Axle Specifications
40' Trailer	148	43,333	Tandem Axle
40' 102" Trailer	39	46,013	Tandem Axle
45' Trailer	45	45,000	Tandem Axle
45' 102" Trailer	41	50,100	Triple Axle
40'-65' Expandable Trailer	3	44,100	Tandem Axle
40'-65' Expandable Trailer	2	50,680	Triple Axle
40' Lowboy Trailer	5	42,725	Triple Axle
45' Lowboy Trailer	2	45,660	Triple Axle
53' 102" Trailer	29	53,320	Triple Axle

Insulated Equipment	Fleet Size	Capacity Cube	Capacity Weight	Interior Length	Interior Width	Interior Height	Door Width	Door Height	Axle Specifications
30' 102" Trailer	100	2,238	43,000	29'1"	8'2"	9'4"	8'2"	9'4"	Tandem Axle
40' Trailer Type 2	103	2,317	48,000	39'1"	7'4"	8'1"	7'4"	7'11"	Tandem Axle
40' Container With Chassis	45	2,500	46,200	38'10"	7'6"	8'7"	7'6"	8'3"	Tandem Axle
45' 102" Trailer	111	3,293	50,553	44'1"	8'2"	9'4"	8'2"	9'4"	Tandem Axle
48' 102" Trailer	34	3,138	52,013	46'10"	8'0"	8'5"	8'0"	8'4"	Tandem Axle
53' 102" Trailer	369	4,024	50,840	52'3"	8'2"	9'4"	8'2"	9'4"	Tandem Axle

Refrigerated Equipment	Fleet Size	Capacity Cube	Capacity Weight	Interior Length	Interior Width	Interior Height	Door Width	Door Height	Axle Specifications	Volts Three-Phase
30' 102" Trailer Type 4	108	2,079	39,353	28'0"	8'2"	9'1"	8'1"	9'1"	Tandem Axle	460
40' 102" Trailer Type 4	41	2,222	44,300	37'5"	7'11"	7'6"	7'11"	8'0"	Tandem Axle	230
40' Container With Chassis	80	2,393	43,880	38'1"	7'6"	8'4"	7'6"	8'4"	Tandem Axle	460
45' 102" Trailer	83	2,853	47,833	43'0"	8'1"	8'2"	8'0"	8'2"	Tandem Axle	230, 460
53' 102" Trailer	109	3,850	51,860	52'2"	8'1"	9'1"	8'1"	9'0"	Triple Axle	460

\* Cube and maximum weight may vary depending upon specific trailer series number.